

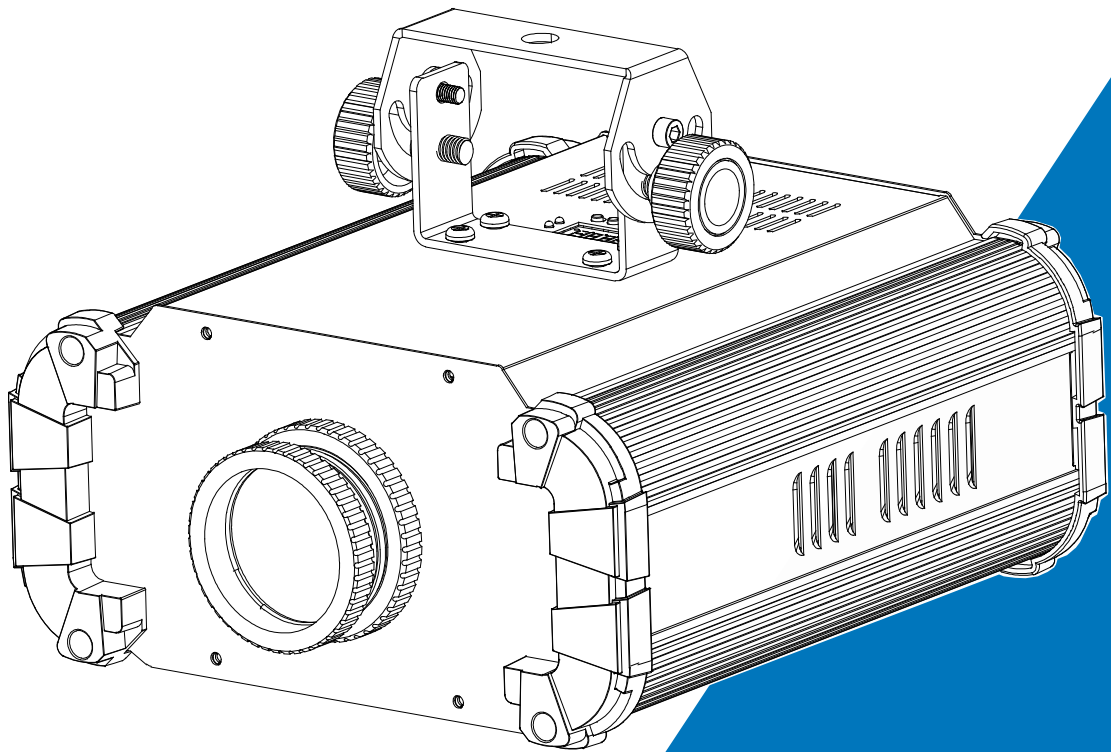

LED WAVE 100

LED-WAV-100W



User Manual

Please read the instruction carefully before use

CONTENTS

1. Safety Instruction	2
2. Technical Specification	3
3. How To Set The Unit.....	4
3.1 Control Panel	4
3.2 Lens Installation	5
3.3 Main Function	6
4. How To Control The Unit.....	10
4.1 Master/Slave Built In Preprogrammed Function	10
4.2 Easy Controller	10
4.3 DMX Controller	11
4.4 DMX 512 Configuration.....	11
4.5 DMX512 Connection	12
5. Troubleshooting.....	13
6. Fixture Cleaning	14

1. Safety Instruction



Please read this instruction carefully which includes important information about the installation, usage and maintenance.

WARNING

Please keep this User Guide for future consultation. If you sell the unit to another user, be sure that they also receive this instruction booklet.

- Unpack and check carefully there is no transportation damage before using the unit.
- Before operating, ensure that the voltage and frequency of power supply match the power requirements of the unit.
- It's important to ground the yellow/green conductor to earth in order to avoid electric shock.
- The unit is for indoor use only. Use only in a dry location.
- The unit must be installed in a location with adequate ventilation, at least 50cm from adjacent surfaces. Be sure that no ventilation slots are blocked.
- Disconnect main power before replacement or servicing.
- Make sure there are no flammable materials close to the unit while operating as it is fire hazard.
- Use safety cable when fixes this unit. DO NOT handle the unit by taking its head only, but always by taking its base.
- Maximum ambient temperature is $T_a: 40^{\circ}\text{C}$. DO NOT operate it where the temperature is higher than this.
- Unit surface temperature may reach up to 75°C . DO NOT touch the housing bare-hand during its operation. Turn off the power and allow about 15 minutes for the unit to cool down before replacing or serving.
- In the event of serious operating problem, stop using the unit immediately. Never try to repair the unit by yourself. Repairs carried out by unskilled people can lead to damage or malfunction. Please contact the nearest authorized technical assistance center. Always use the same type spare parts.
- DO NOT touch any cables during operation as high voltage may cause electric shock.

Warning:

- To prevent or reduce the risk of electrical shock or fire, do not expose the unit to rain or moisture.
- The housing, the lenses, or the ultraviolet filter must be replaced if they are visibly damaged.

Caution:

There are no user serviceable parts inside the unit. Do not open the housing or attempt any repairs yourself. In the unlikely event your unit may require service, please contact your nearest dealer.

Installation:

The unit should be mounted via its Omega Quick Release Clamp bracket. Always ensure that the unit is firmly fixed to avoid vibration and slipping while operating. Make sure that the structure to which you are attaching the unit is secure and is able to support a weight of 10 times of the fixtures weight. Also always use a safety cable that can hold 12 times of the weight of the unit when installing the fixture.

The equipment must be installed by professionals. It must be installed in a place where is out of the reach of people and no one can pass by or under it.

2. Technical Specification

- ◇ The “high power” LED Water wave effect is suitable for big clubs, stages, and events.
- ◇ Different working modes:
 - Standalone: no DMX-controller needed
 - Master/Slave: great synchronized shows, no DMX-controller required
 - DMX: 3 channels
- ◇ Color wheel with 5 colors plus open
- ◇ Two different beam angles (standard 44° or 29°) available
- ◇ LED display for easy navigation
- ◇ High efficiency and low power consumption

- ◇ **Input Voltage:** AC 100V~240V, 50/60Hz
- ◇ **Power Consumption:** 107W
- ◇ **Light Source:** 90W LED
- ◇ **Weight:** 6.2kgs / 13.7lbs
- ◇ **Dimension:** 271 x 309 x 210 mm / 10.7" x 12.2" x 8.3" in

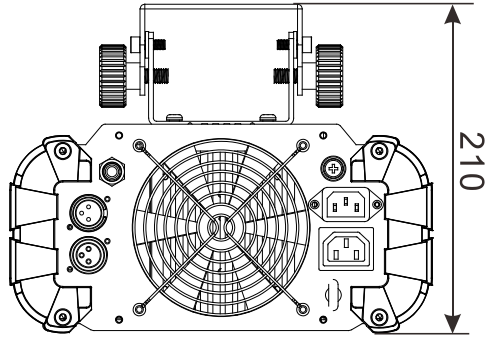
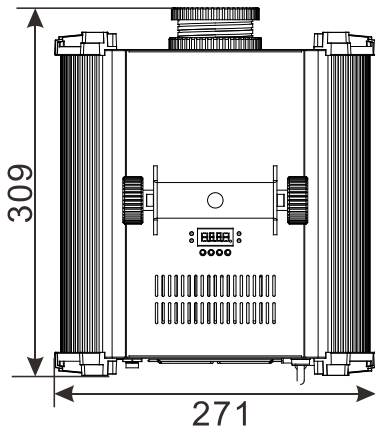

3. How To Set The Unit

3.1 Control Panel

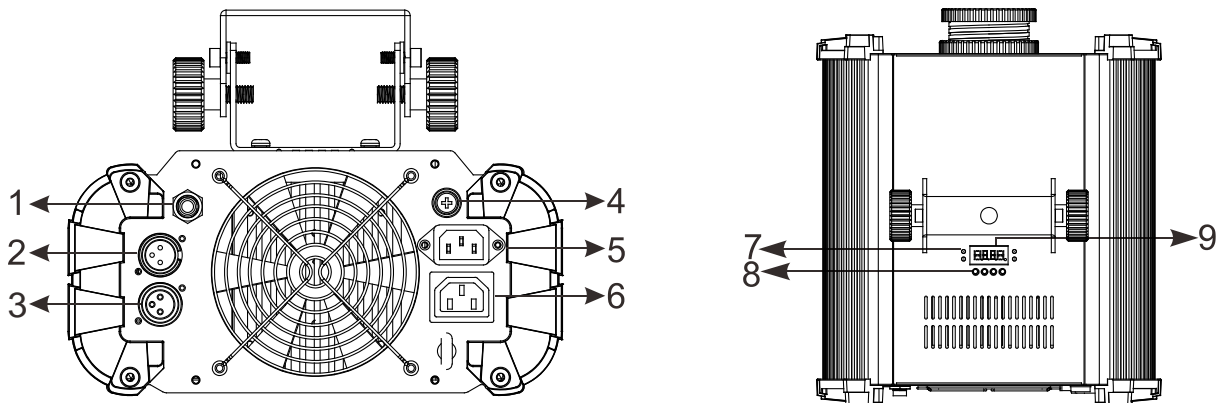

1. Only for remote control:

Connects to optional CA-8 to control the unit in Standby, Function and Strobe/Blackout modes

2. DMX IN:

DMX512 link, use 3-pin XLR cable to link the unit and the DMX controller

3. DMX OUT:

DMX512 link, use 3-pin XLR cable to link the next unit and output DMX signal

4. Fuse (T 3.15A):

Protects the unit from over-voltage or short circuit

5. MAINS IN:

Connection from main power supply

6. MAINS OUT:

Connection for main power supply to the next unit

7. LED:

DMX	On	DMX input present
MASTER	On	Master Mode
SLAVE	On	Slave Mode
SOUND	Flashing	Sound activation

8. Button:

MENU	To select the programming functions
▼ DOWN	To go backward in the selected functions
▲ UP	To go forward in the selected functions
ENTER	To confirm the selected functions

9. Function Display:

To show the various menus and the selected functions;

3.2 Lens Installation

A. Product Items

- User manual
- 29° lens

B. Mounting

You can install the unit on the truss or ceiling; Use clamps to fix the unit to truss. Always ensure that the unit is firmly fixed to avoid vibration and slipping while operating. Always ensure that the structure to which you are attaching the unit is secure. Also always use a safety cable that can hold 10 times of the weight of the unit when installing the fixture.

C. Replace the lens

You could replace the other lens if you want to, as following picture.

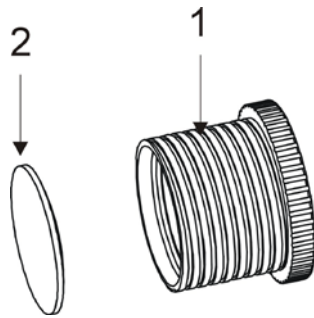

You should screw the lens roller to take it down as NO.1, and bring the lens out as No.2. Then you could replace the lens that you want to.

Notes: the lens roller has two slots for the lens; you should pay more attention that the latest slot is for the 29° lens, and the far slot is for 44° lens.

3.3 Main Function

To select any of the given functions, press the **MENU** button up to when the required selection as shown on the display. Select the function by the **ENTER** button and the display will blink. Use the **DOWN/UP** button to change the mode. Once the required mode has been selected, press the **ENTER** button to setup, to go back to the functions without any change press the **MENU** button again. Press and hold the **MENU** button for about one second or wait for one minute to exit the menu mode.

The main functions are shown below:

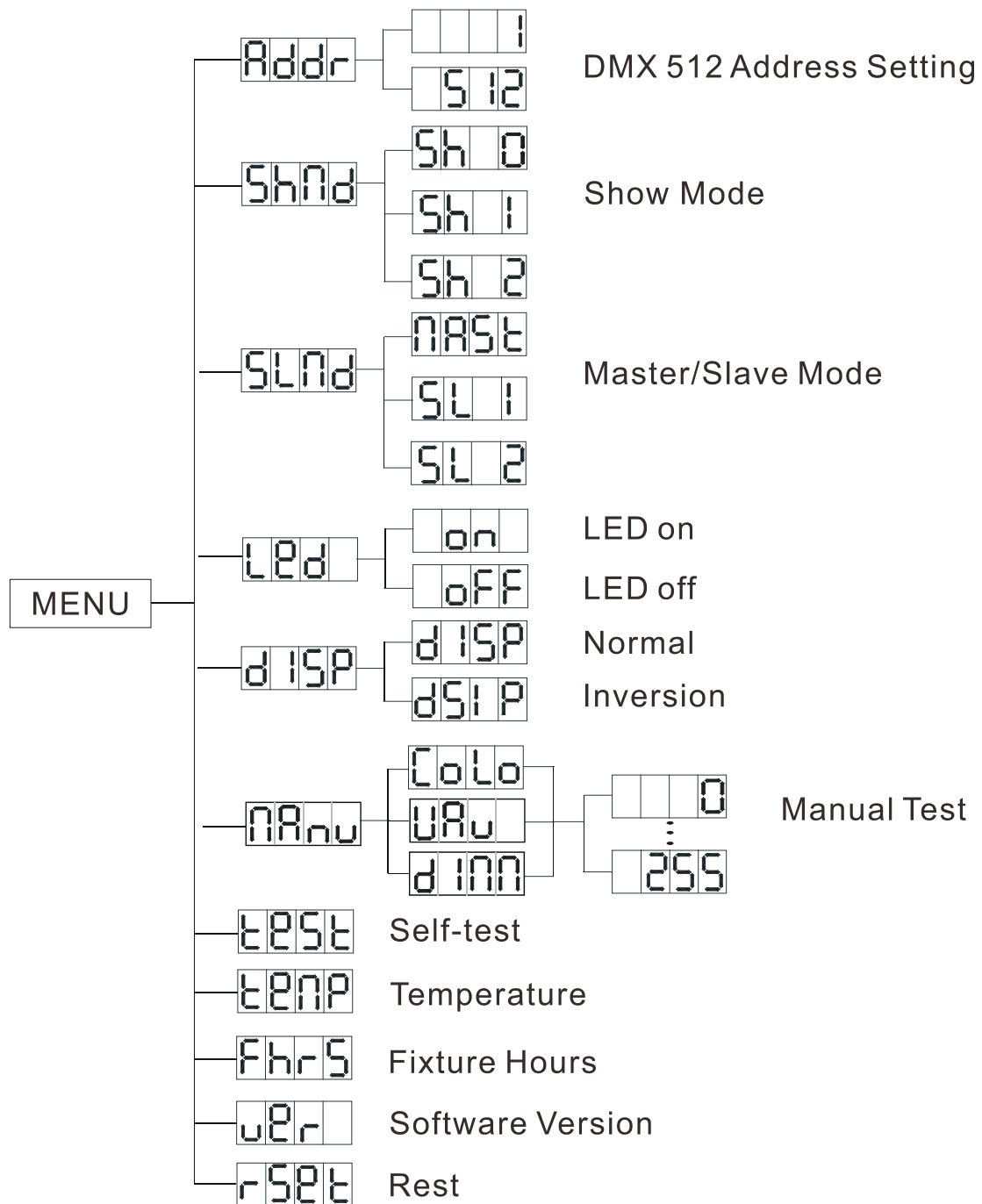

Addr DMX 512 Address Setting

Press the MENU button up to when the **Addr** is shown on the display. Pressing ENTER button and the display will blink. Use DOWN and UP button to change the DMX 512 address. Once the address has been selected, press ENTER button to setup or automatically exit menu mode without any change after one minute. Back to the previous functions without any change press MENU button.

SHNd Show Mode

Press the MENU button up to when the **SHNd** is showing on the display. Pressing ENTER button and the display will blink. Use DOWN and UP button to select the **Sh 0** (Random show), **Sh 1** (show 1) or **Sh 2** (show 2). Once the mode has been selected, press the ENTER button to setup or automatically return to the main functions without any change after one minute. To go back to the functions without any change press the MENU button again.

SLNd Master/Slave Mode

Press the MENU button up to when the **SLNd** is showing on the display. Pressing ENTER button and the display will blink. Use DOWN and UP button to select the **MASt** (set the fixture as master), **SL 1** (set the fixture as slave 1) or **SL 2** (set the fixture as slave 2). Once the mode has been selected, press the ENTER button to setup or automatically return to the main functions without any change after one minute. To go back to the functions without any change press the MENU button again.

LEd LED Display





Press the MENU button up to when the **LEd** is shown on the display. Pressing ENTER button and the display will blink. Use DOWN and UP button to select **On** (display always on) or **OFF** (display off 20 seconds after exit menu) mode. Once select, press ENTER button to setup or exit menu mode without any change after one minute. Back to the functions without any change press MENU button again.

dISP Display Inverse

Press MENU button until **dISP** is blinking on the display. Use DOWN and UP button to select **no** (display normal) or **YES** (display inverse), press ENTER button to setup.



Manual Test

Press the MENU button up to when the  is shown on the display. Pressing ENTER button, and use DOWN and UP button to select  (0-255) or  (000-255, clockwise/counterclockwise) or  (000-255), press ENTER button to confirm and use DOWN and UP button to adjust the value, once select press ENTER button to setup or automatically exit menu mode without any change after one minute. To go back to the last function without any change press the MENU button.



Self-test

Press the MENU button up to when the  is shown on the display, Pressing ENTER button to run the auto test. Back to the functions without any change press MENU button. Back to the functions without any change press MENU button.



Temperature

Press the MENU button up to when the  is blinking on the display. Pressing ENTER button and the display will show the temperature of the unit. To go back to the functions press the MENU button again.

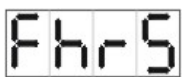

Fixture Hours

Press the MENU button up to when the  is blinking on the display. Pressing ENTER button and the display will show the number of working hours of the unit. To go back to the functions press the MENU button.



Software Version

Press the MENU button up to when the  is showing on the display. Pressing ENTER button and the display will show the version of software of the unit. To go back to the functions press the MENU button again.



Press the MENU button up to when the  is shown on the display, press ENTER button to setup. Back to the functions without any change press MENU button.

4. How To Control The Unit

You can operate the unit in three ways:

1. By master/slave built-in preprogram function
2. By easy controller
3. By DMX controller

No need to turn the unit off when you change the DMX address, as new DMX address setting will be effected at once. Every time you turn the unit on, it will show “CP21” on the display and move all the motors to their ‘home’ position. After that the unit will be ready to receive DMX signal or run the built in programs.

4.1 Master/Slave Built In Preprogrammed Function

The fixture will allow you to link 2 fixtures together and operate without a controller. In Master/Slave mode, the first fixture whose DMX input jack has with nothing connect need to set as master and the other unit need to set as slave 1 via menu, then the first unit will control the other to give an automatic and synchronized light show. This function is good when you want an instant show. Any fixture can act as a Master or as a Slave.

4.2 Easy Controller

The easy remote control is used only in master/slave mode. By connecting to the 1/4” microphone jack of the first unit, you will find that the remote controller on the first unit will control all the other units for Standby, Function and Mode selection.

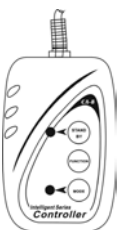

Stand By	Blackout the unit	
Function	1. Fast Sync. Strobe 2. Medium Sync. Strobe 3. Slow Sync. Strobe	Show 0 - 2
Mode	LED OFF	LED blinking

4.3 DMX Controller

Use universal DMX controller to control the units, you have to set DMX address from 1 to 512 channel so that the units can receive DMX signal.

Press the MENU button up to when the **Addr** is showing on the display. Pressing ENTER button and the display will blink. Use DOWN and UP button to change the DMX512 address. Once the address has been selected, press and keep ENTER button pressed up to when the display stops blinking or storing automatically one minute later. To go back to the functions without any change press the MENU button again. If you use please refer to the following diagram to address your DMX512 channel for the first 4 units.



4.4 DMX 512 Configuration

3 Channel Mode:

CHANNEL	VALUE	FUNCTIONS
1	000 ~ 255	DIMMER 0 → 100%
2	000 ~ 009 010 ~ 120 121 ~ 134 135 ~ 245 246 ~ 255	Diamond Wheel Stop CW Rotation: fast → slow Stop CCW Rotation: slow → fast Stop
3	000 ~ 010 010 ~ 021 022 ~ 032 033 ~ 043	Color Wheel Open Open → Color 1 Color 1 Color 1 → Color 2

	044 ~ 054	Color 2
	055 ~ 065	Color 2 → Color 3
	066 ~ 076	Color 3
	077 ~ 087	Color 3 → Color 4
	088 ~ 098	Color 4
	099 ~ 109	Color 4 → Color 5
	110 ~ 120	Color 5
	121 ~ 127	Color 5 → Open
		Continuous Rotation
	128 ~ 187	CW Rotation: fast → slow
	188 ~ 196	Stop
	197 ~ 255	CCW Rotation: slow → fast

4.5 DMX512 Connection

The DMX512 is widely used in intelligent lighting control, with a maximum of 512 channels.

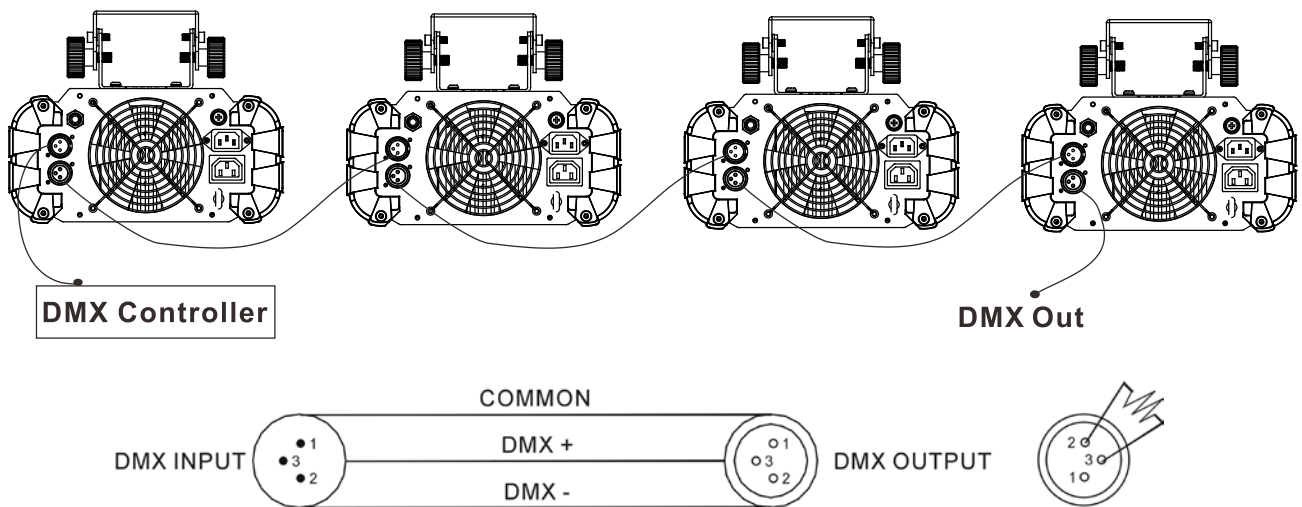

ATTENTION

Termination reduces signal errors and to avoid signal transmission problems and interference. It is always advisable to connect a DMX terminal (Resistance 120 ohm 1/4W between pin2 (DMX-) and pin3 (DMX+) of the last fixture).

1. If you using a controller with 5 pins DMX output, you need to use a 5 to 3 pin adapter-cable.
2. The last units DMX cable has to be terminated with a 120 ohm 1/4W resistor between pin 2(DMX-) and pin 3(DMX+) of a 3-pin XLR-plug and plug it in the DMX-output of the last unit.

3. Connect the unit together in a `daisy chain` by XLR plug from the output of the unit to the input of the next unit. The cable can not be branched or split to a `Y` cable. DMX 512 is a very high-speed signal. Inadequate or damaged cables, soldered joints or corroded connectors can easily distort the signal and shut down the system.
4. The DMX output and input connectors are pass-through to maintain the DMX circuit, when one of the units' power is disconnected.
5. Each fixture unit needs to have an address set to receive the data sent by the controller. The address number is between 0-511 (usually 0 & 1 are equal to 1).
6. The end of the DMX 512 system should be terminated to reduce signal errors.
7. 3 pin XLR connectors are more popular than 5 pin XLR.
3 pin XLR: Pin 1: GND, Pin 2: Negative signal (-), Pin 3: Positive signal (+)
5 pin XLR: Pin 1: GND, Pin 2: Negative signal (-), Pin 3: Positive signal (+),
Pin 4/Pin 5: Not used.

5. Troubleshooting

Following are a few common problems that may occur during operation. Here are some suggestions for easy troubleshooting:

A. The unit does not work, no light and the fan does not work

1. Check the connection of power and main fuse.
2. Measure the mains voltage on the main connector.
3. Check the power on LED.

B. Not responding to DMX controller

1. DMX LED should be on. If not, check DMX connectors, cables to see if link properly.
2. If the DMX LED is on and no response to the channel, check the address settings and DMX polarity.
3. If you have intermittent DMX signal problems, check the pins on connectors or on PCB of the unit or the previous one.
4. Try to use another DMX controller.
5. Check if the DMX cables run near or run alongside to high voltage cables that may cause

damage or interference to DMX interface circuit.

C. Some units don't respond to the easy controller

1. You may have a break in the DMX cabling. Check the LED for the response of the master/slave mode signal.
2. Wrong DMX address in the unit. Set the proper address.

D. One of the channels is not working well

1. The stepper motor might be damaged or the cable connected to the PCB is broken.
2. The motor's drive IC on the PCB might be out of condition.

6. Fixture Cleaning

The cleaning must be carried out periodically to optimize light output. Cleaning frequency depends on the environment in which the fixture operates: damp, smoky or particularly dirty surrounding can cause greater accumulation of dirt on the unit's optics.

- Clean with soft cloth using normal glass cleaning fluid.
- Always dry the parts carefully.
- Clean the external optics at least every 30 days.

Innovation, Quality, Performance