

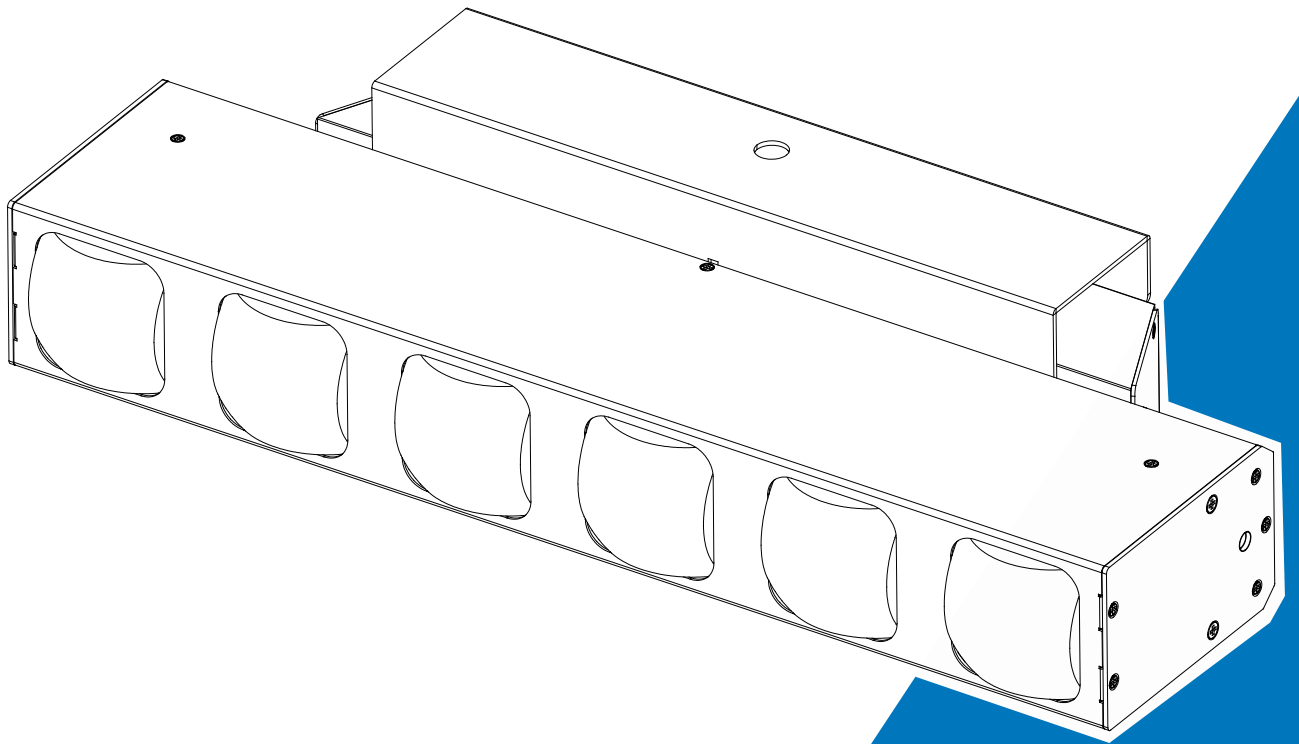

# DOTCHAIN 640



## User Manual

Please read the instruction carefully before use

## CONTENTS

1. Safety Instructions .....	2
2. Technical Specifications.....	4
3. Control Panel .....	5
4. How to Set the Unit.....	6
4.1 Main Function .....	6
4.2 Home Position Adjustment.....	13
5. Control by Universal DMX Controller.....	16
5.1 DMX512 Connections.....	16
5.2 Address Setting .....	17
5.3 DMX512 Configuration.....	17
6. Error Information .....	27
7. Troubleshooting.....	27
8. Fixture Cleaning .....	28

## 1. Safety Instructions



Please read the instruction carefully which includes important information about the installation, usage and maintenance.

### WARNING

Please keep this User Manual for future consultation. If you sell the unit to another user, be sure that they also receive this manual.

### Important:

**Damages caused by the disregard of this user manual are not subject to warranty. The dealer will not accept liability for any resulting defects or problems.**

- Unpack and check carefully to ensure that there is no transportation damage before using the unit.
- This product is for indoor use only. Use only in a dry location.
- DO install and operate by qualified operator.
- DO NOT allow children to operate the fixture.
- Use safety chain when fixing the unit. Handle the unit by carrying its base instead of head only.
- The unit must be installed in a location with adequate ventilation, at least 50cm from adjacent surfaces.
- Be sure that no ventilation slots is blocked, otherwise the unit will be overheated.
- Before operation, ensure that you are connecting this product to the proper voltage in accordance with the specifications in this manual or on the product's specification label.
- It's important to ground the yellow/green conductor to earth in order to avoid electric shock.
- Minimum ambient temperature TA: 0°C. Maximum ambient temperature TA: 40°C. Do not operate this product at a lower or higher temperature.
- DO NOT connect the device to any dimmer pack.
- Keep flammable materials away from the fixture while operating to avoid fire hazard.
- Make sure the power cord is not crimped or damaged; replace it immediately if damaged.
- Unit's surface temperature may reach up to 65°C. DO NOT touch the housing bare-handed during its operation.
- Avoid any flammable liquids, water or metal from entering the unit. Once it happens, cut off

the mains power immediately.

- DO NOT operate in a dirty or dusty environment. DO clean the fixture regularly.
- DO NOT touch any wire during operation as there might be a hazard of electric shock.
- Avoid entanglement of the power cord with other wires.
- The minimum distance to objects/surface must be more than 0.5 meters.
- In the event of serious operating problem, stop using the unit immediately.
- Never turn on and off the unit time after time.
- The housing, the lenses, or the ultraviolet filter must be replaced if they are visibly damaged.
- DO NOT open the housing as there are no user serviceable parts inside.
- DO NOT attempt to operate this unit if it becomes damaged. DO NOT attempt any repairs yourself. Repairs carried out by unskilled people can lead to damage or malfunction. Please contact the nearest authorized technical assistance center if needed.
- Disconnect this product from its power source before servicing.
- DO use the original packaging if the device is to be transported.
- Avoid direct eye exposure to the light source while the product is on.
- DO NOT operate this product if you see damage on the housing, shields, or cables. Have the damaged parts replaced by an authorized technician at once.

**Installation:**

The fixture should be fixed on the clamp. Always ensure that the unit is firmly fixed to avoid vibration and slipping off during operation. Ensure that the trussing or area of installation must be able to hold 10 times the weight without any deformation. Always install a safety cable that can hold at least 12 times the weight of the fixture when installing.

DO install and operate by qualified operator. It must be installed in a place where there is out of the reach of people.

## 2. Technical Specifications

### Power Voltage:

180-240V~ 50/60Hz

### Power Consumption:

210W

### Light Source:

6x40W RGBW LED

### Beam Angle:

3°

### Control:

DMX Channel: 26/10/8/6 Channels

Control Mode: DMX512, RDM, Art-Net, sACN

Firmware Upgrade via DMX link

### Construction:

Display: OLED display

Data In/Out: 3-pin XLR (5-pin XLR is optional); RJ45

Power In/Out: Power Connector in

Protection Rating: IP20

### Features:

6 LEDs can be controlled individually

Smooth dimming from 0-100%

Outstanding strobe effect with variable speed

### Dimension/Weight:

500x72.5x217mm, 5.6kgs

19.7"x2.9"x8.5" in, 12.4lbs

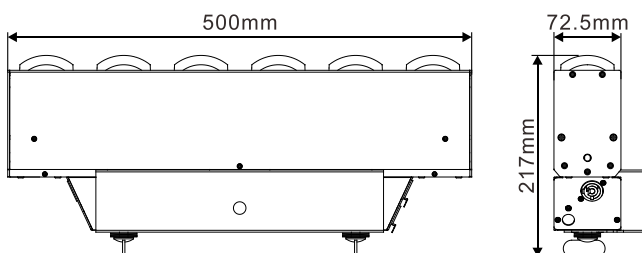

**Photometric Diagram:**

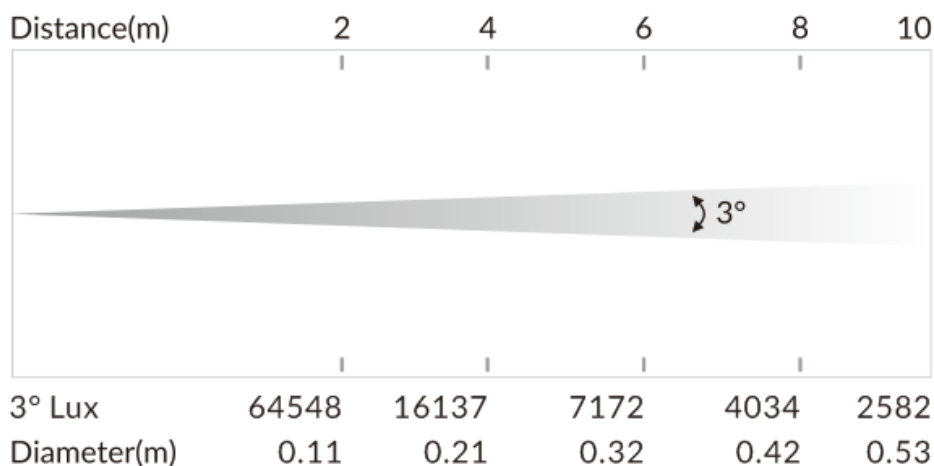

**3. Control Panel**

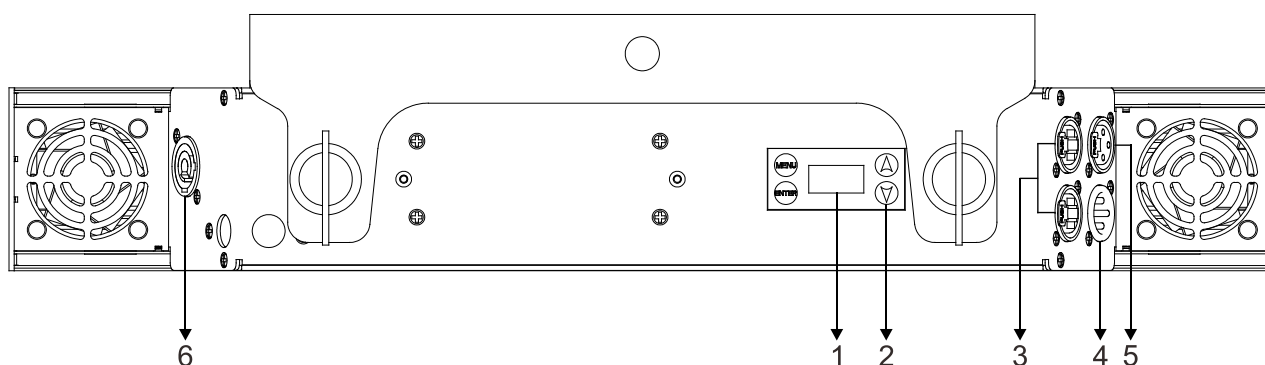

**1. DISPLAY:** To show the various menus and the selected functions

**2. Button:**

<b>MENU</b>	To select the programming functions
<b>▲ UP</b>	To go backward in the selected functions
<b>▼ DOWN</b>	To go forward in the selected functions
<b>ENTER</b>	To confirm the selected functions

**3. ETHERNET:** Transfers fixture’s information to a main controller

**4. DMX IN:**

For DMX512 link, use 3-pin XLR cable to link the unit and DMX controller (5-pin XLR is optional)

**5. DMX OUT:**

For DMX512 link, use 3-pin XLR cable to link the next units (5-pin XLR is optional)

**6. POWERCON IN:** To connect to supply power

## **4. How to Set the Unit**

### **4.1 Main Function**

Turn on the unit, press the MENU button into menu mode, and press the UP/DOWN button until the required function is shown on the monitor. Select the function by pressing the ENTER button. Use the UP/DOWN button to choose the submenu, press the ENTER button to store and automatically return to the last menu. Press the MENU button or let the unit idle 30 seconds to exit menu mode.

The main functions are shown below:

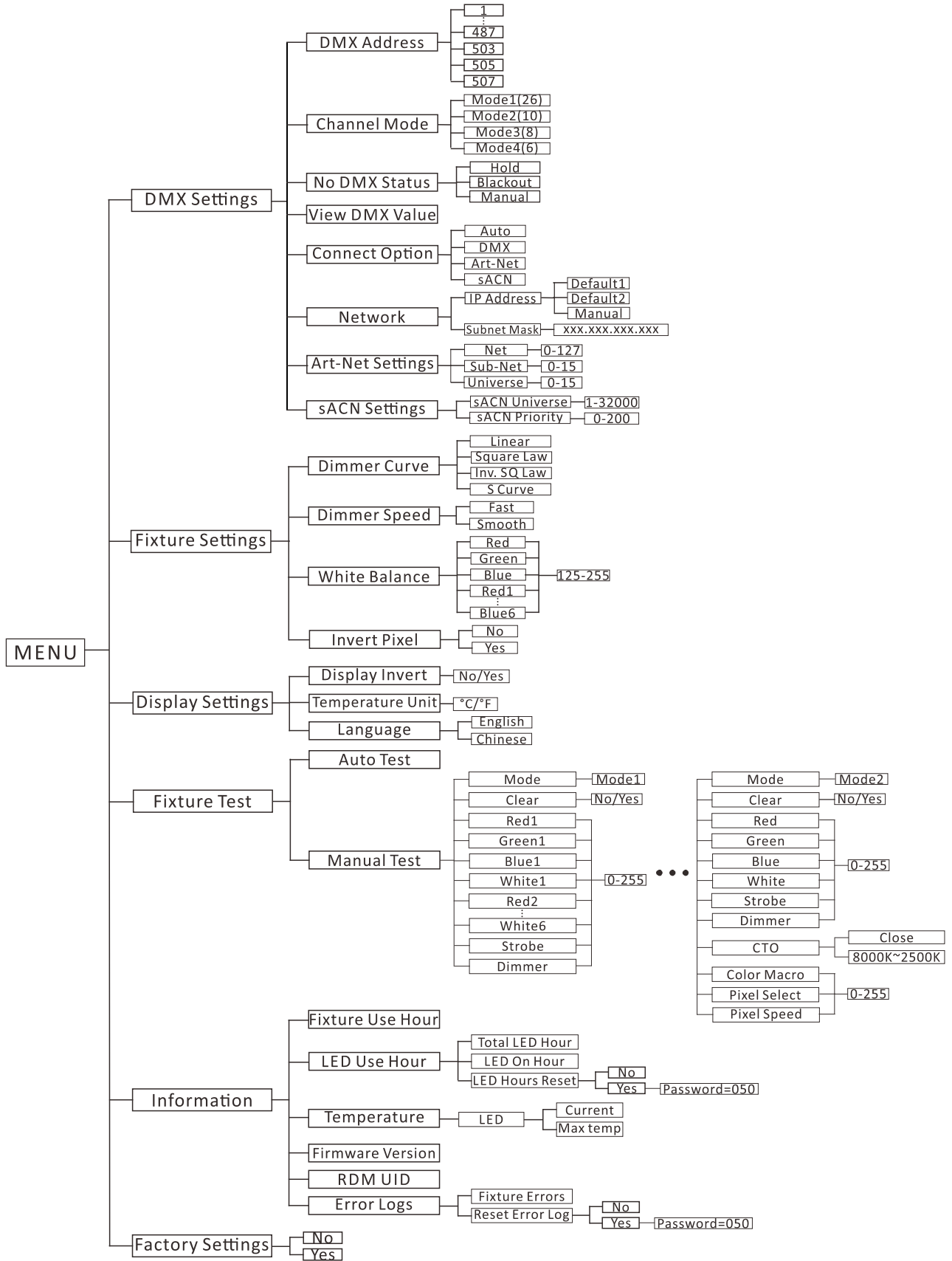



## ***DMX Settings***

To select **DMX Settings**, press the **ENTER** button to confirm, use the **UP/DOWN** button to select **DMX Address, Channel Mode, No DMX Status, View DMX Value, Connect Option, Network, Art-Net Settings** or **sACN Settings**.

### **DMX Address**

To select **DMX Address**, press the **ENTER** button to confirm. Use the **UP/DOWN** button to adjust the address from **001** to **487/503/505/507**, press the **ENTER** button to store. Press the **MENU** button back to the last menu or let the unit idle 30 seconds to exit menu mode.

### **Channel Mode**

To select **Channel Mode**, press the **ENTER** button to confirm. Use the **UP/DOWN** button to select **Mode1(26), Mode2(10), Mode3(8)** or **Mode4(6)**, press the **ENTER** button to store. Press the **MENU** button back to the last menu or let the unit idle 30 seconds to exit menu mode.

### **No DMX Status**

To select **No DMX Status**, press the **ENTER** button to confirm. Use the **UP/DOWN** button to select **Hold**(fixture continues to obey the last command it received Via DMX if DMX signal stops), **Blackout**(fixture blacks out if DMX signal stops) or **Manual**(the fixture will automatically read the DMX value in the “Manual Test” menu for operation after selecting this mode), press the **ENTER** button to store. Press the **MENU** button back to the last menu or let the unit idle 30 seconds to exit menu mode.

### **View DMX Value**

To select **View DMX Value**, press the **ENTER** button to confirm. Use the **UP/DOWN** button to view the DMX channel value. Press the **MENU** button back to the last menu or let the unit idle 30 seconds to exit menu mode.

### **Connect Option**

To select **Connect Option**, press the **ENTER** button to confirm. Use the **UP/DOWN** button to select **Auto, DMX, Art-Net** or **sACN**, press the **ENTER** button to store. Press the **MENU** button back to the last menu or let the unit idle 30 seconds to exit menu mode.

## Network

To select **Network**, press the **ENTER** button to confirm. Use the **UP/DOWN** button to select **IP Address** or **Subnet Mask**, press the **ENTER** button to store. Press the **MENU** button back to the last menu or let the unit idle 30 seconds to exit menu mode.

## Art-Net Settings

To select **Art-Net Settings**, press the **ENTER** button to confirm. Use the **UP/DOWN** button to select **Net**, **Subnet** or **Universe**, press the **ENTER** button to store. Press the **MENU** button back to the last menu or let the unit idle 30 seconds to exit menu mode.

## sACN Settings

To select **sACN Settings**, press the **ENTER** button to confirm. Use the **UP/DOWN** button to select **sACN Universe** or **sACN Priority**, press the **ENTER** button to store. Press the **MENU** button back to the last menu or let the unit idle 30 seconds to exit menu mode.

## Fixture Settings

To select **Fixture Settings**, press the **ENTER** button to confirm. Use the **UP/DOWN** buttons to select **Dimmer Curve**, **Dimmer Speed**, **White Balance** or **Invert Pixel**.

### Dimmer Curve

To select **Dimmer Curve**, press the **ENTER** button to confirm. Use the **DOWN/UP** button to select **Linear**, **Square Law**, **Inv SQ Law** or **S Curve**, press the **ENTER** button to store. Press the **MENU** button back to the last menu or let the unit idle 30 seconds to exit menu mode.

### Dimmer Modes

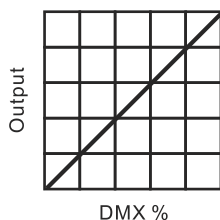

Optically Linear

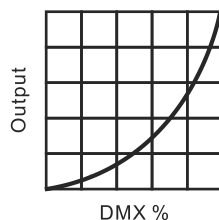

Square Law

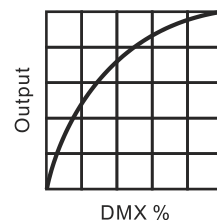

Inverse Square Law

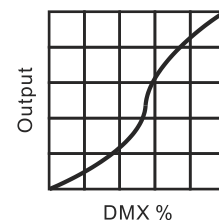

S-curve

**Optically Linear:** The increase in light intensity appears to be linear as DMX value is increased.

**Square Law:** Light intensity control is finer at low levels and coarser at high levels.

**Inverse Square Law:** Light intensity control is coarser at low levels and finer at high levels.

**S-Curve:** Light intensity control is finer at low levels and high levels and coarser at medium levels.

### **Dimmer Speed**

To select **Dimmer Speed**, press the **ENTER** button to confirm. Use the **UP/DOWN** button to select **Fast** or **Smooth**, press the **ENTER** button to store. Press the **MENU** button back to the last menu or let the unit idle 30 seconds to exit menu mode.

### **White Balance**

To select **White Balance**, press the **ENTER** button to confirm. Use the **UP/DOWN** button to select **Red**, **Green**, **Blue**, **Red1**, **Green1**, **Blue1.....** or **Blue6**, press the **ENTER** button to confirm, use the **UP/DOWN** button to adjust the value from **125** to **255**, press the **ENTER** button to store. Press the **MENU** button back to the last menu or let the unit idle 30 seconds to exit menu mode.

### **Invert Pixel**

To select **Invert Pixel**, press the **ENTER** button to confirm. Use the **UP/DOWN** button to select **No** or **Yes**, press the **ENTER** button to store. Press the **MENU** button back to the last menu or let the unit idle 30 seconds to exit menu mode.

## ***Display Settings***

To select **Display Settings**, press the **ENTER** button to confirm, use the **UP/DOWN** button to select **Display Invert**, **Temperature Unit** or **Language**.

### **Display Invert**

Select **Display Invert**, press the **ENTER** button to confirm. Use the **UP/DOWN** button to select **No**(normal display) or **Yes**(invert display), press the **ENTER** button to store. Press the **MENU** button back to the last menu or let the unit idle 30 seconds to exit menu mode.

### **Temperature Unit**

Select **Temperature Unit**, press the **ENTER** button to confirm. Use the **UP/DOWN** button to select **°C** or **°F**, press the **ENTER** button to store. Press the **MENU** button back to the last menu or let the unit idle 30 seconds to exit menu mode.

### **Language**

Select **Language**, press the **ENTER** button to confirm. Use the **UP/DOWN** button to select **English** or **Chinese**, press the **ENTER** button to store. Press the **MENU** button back to the last menu or let the unit idle 30 seconds to exit menu mode.

## ***Fixture Test***

To select **Fixture Test**, press the **ENTER** button to confirm, use the **UP/DOWN** button to select **Auto Test** or **Manual Test**.

### **Auto Test**

Select **Auto Test**, press the **ENTER** button to confirm, the unit will run built-in programs to automatically test its functions. Press the **MENU** button back to the last menu or exit menu mode after auto test.

### **Manual Test**

Select **Manual Test**, press the **ENTER** button to confirm, the present channel will show on the display, use the **UP/DOWN** button to select channel, press the **ENTER** button to confirm, then use the **UP/DOWN** button to adjust the value, press the **ENTER** button to store, the fixture will run as the channel value indicates. Press the **MENU** button back to the last menu or exit menu mode idling 30 seconds.

(The fixture will return to the previous DMX state after exiting Manual Test menu and the Manual Test parameters will be automatically saved after power off and restart.)

## ***Information***

To select **Information**, press the **ENTER** button to confirm, use the **UP/DOWN** button to select **Fixture Use Hour**, **LED Use Hour**, **Temperature**, **Firmware Version**, **RDM UID** or **Error Logs**.

### **Fixture Use Hour**

Select **Fixture Use Hour**, press the **ENTER** button to confirm, fixture use hour will show on the display, press the **MENU** button to exit.

### **LED Use Hour**

To select **LED Use Hour**, press the **ENTER** button to confirm, use the **UP/DOWN** button to select **Total LED Hour**, **LED On Hour** or **LED Hours Reset**, press the **ENTER** button to store. Select **LED Hours Reset**, press the **ENTER** button to confirm. Use the **UP/DOWN** button to select **No** or **Yes**, press the **ENTER** button to store. Select **Yes**, press the **ENTER** button to confirm. Use the **UP/DOWN** button to set the password **050** to reset the LED hours, press the **ENTER** button to store. Press the **MENU** button back to the last menu or exit menu mode let the unit idle 30 seconds.

### **Temperature**

Select **Temperature**, press the **ENTER** button to confirm, use the **UP/DOWN** button to select **LED**, press the **ENTER** button to store, LED's current temperature or max temperature will show on the display, press the **MENU** button to exit.

### **Firmware Version**

Select **Firmware Version**, press the **ENTER** button to confirm, firmware version will show on the display, press the **MENU** button back to exit.

### **RDM UID**

Select **RDM UID**, press the **ENTER** button to confirm, RDM UID will show on the display, press the **MENU** button back to exit.

### **Error Logs**

Select **Error Logs**, press the **ENTER** button to confirm. Use the **UP/DOWN** button to select **Fixture Errors** or **Reset Error Log**, press the **ENTER** button to store. Select **Reset Error Log**, press the **ENTER** button to confirm. Use the **UP/DOWN** button to select **No** or **Yes**, press the **ENTER** button to store. Select **Yes**, press the **ENTER** button to confirm. Use the **UP/DOWN** button to set the password **050**, press the **ENTER** button to store. Press the **MENU** button back to the last menu or let the unit idle 30 seconds to exit menu mode.

### ***Factory Settings***

To select **Factory Settings**, press the **ENTER** button to confirm, use the **UP/DOWN** button to select **No**(normal) or **Yes** (the fixture will reset to factory settings), press **ENTER** button to store. Press the **MENU** button to exit.

## **RDM FUNCTIONS**

Select the MANUFACTURER menu to display the manufacturer of the fixture.

Select the SOFTWARE VERSION menu and the program version number of the fixture will be displayed.

Select the DMX START ADDRESS menu to change the DMX 512 address (001-512).

Select the DEVICE MODEL DESCRIPTION menu to display the model of the fixture.

Select the DEVICE LABEL menu to change the model of the fixture.

Select the DMX PERSONALITY menu to set the channel mode of the fixture (26/10/8/6 channel).

Select the DMX PERSONALITY DESCRIPTION menu to display the current channel mode of the fixture.

Select the DEVICE HOURS menu to display the running time of the fixture.

Select the RESET DEVICE menu, the WARM RESET/COLD RESET option will be displayed. When WARM RESET is selected, the fixture will start a warm reset, and exit when COLD RESET is selected.

## **4.2 Home Position Adjustment**

Press the MENU button into menu mode, then press the ENTER button for about 3 seconds into offset mode to adjust the home position. Select the function by pressing the ENTER button. Use the UP/DOWN button to choose the submenu, press the ENTER button to store and automatically return to the last menu. Press MENU button to exit.

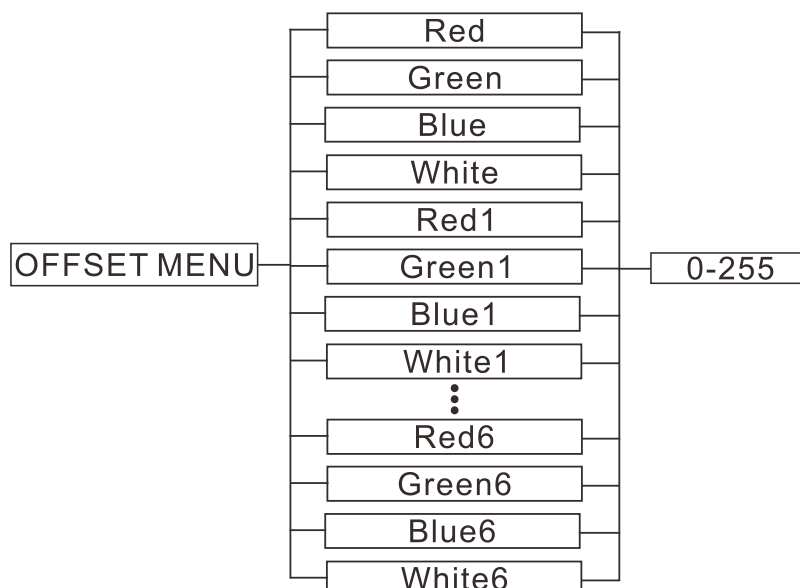

### **Red**

Enter offset mode, Select **Red**, press the **ENTER** button to confirm, the present position will blink on the display, use the **UP/DOWN** button to offset the value from 0 to 255, press the **ENTER** button to store. Press the **MENU** button to exit.

### **Green**

Enter offset mode, Select **Green**, press the **ENTER** button to confirm, the present position will blink on the display, use the **UP/DOWN** button to offset the value from 0 to 255, press the **ENTER** button to store. Press the **MENU** button to exit.

### **Blue**

Enter offset mode, Select **Blue**, press the **ENTER** button to confirm, the present position will blink on the display, use the **UP/DOWN** button to offset the value from 0 to 255, press the **ENTER** button to store. Press the **MENU** button to exit.

### **White**

Enter offset mode, Select **White**, press the **ENTER** button to confirm, the present position will blink on the display, use the **UP/DOWN** button to offset the value from 0 to 255, press the **ENTER** button to store. Press the **MENU** button to exit.

### **Red1**

Enter offset mode, Select **Red1**, press the **ENTER** button to confirm, the present position will blink on the display, use the **UP/DOWN** button to offset the value from 0 to 255, press the **ENTER** button to store. Press the **MENU** button to exit.

### **Green1**

Enter offset mode, Select **Green1**, press the **ENTER** button to confirm, the present position will blink on the display, use the **UP/DOWN** button to offset the value from 0 to 255, press the **ENTER** button to store. Press the **MENU** button to exit.

### **Blue1**

Enter offset mode, Select **Blue1**, press the **ENTER** button to confirm, the present position will blink on the display, use the **UP/DOWN** button to offset the value from 0 to 255, press the **ENTER** button to store. Press the **MENU** button to exit.

### **White1**

Enter offset mode, Select **White1**, press the **ENTER** button to confirm, the present position will blink on the display, use the **UP/DOWN** button to offset the value from 0 to 255, press the **ENTER** button to store. Press the **MENU** button to exit.

.....

### **Red6**

Enter offset mode, Select **Red6**, press the **ENTER** button to confirm, the present position will blink on the display, use the **UP/DOWN** button to offset the value from 0 to 255, press the **ENTER** button to store. Press the **MENU** button to exit.

### **Green6**

Enter offset mode, Select **Green6**, press the **ENTER** button to confirm, the present position will blink on the display, use the **UP/DOWN** button to offset the value from 0 to 255, press the **ENTER** button to store. Press the **MENU** button to exit.

### **Blue6**

Enter offset mode, Select **Blue6**, press the **ENTER** button to confirm, the present position will blink on the display, use the **UP/DOWN** button to offset the value from 0 to 255, press the **ENTER** button to store. Press the **MENU** button to exit.

### **White6**

Enter offset mode, Select **White6**, press the **ENTER** button to confirm, the present position will blink on the display, use the **UP/DOWN** button to offset the value from 0 to 255, press the **ENTER** button to store. Press the **MENU** button to exit.



## 5. Control by Universal DMX Controller

### 5.1 DMX512 Connections

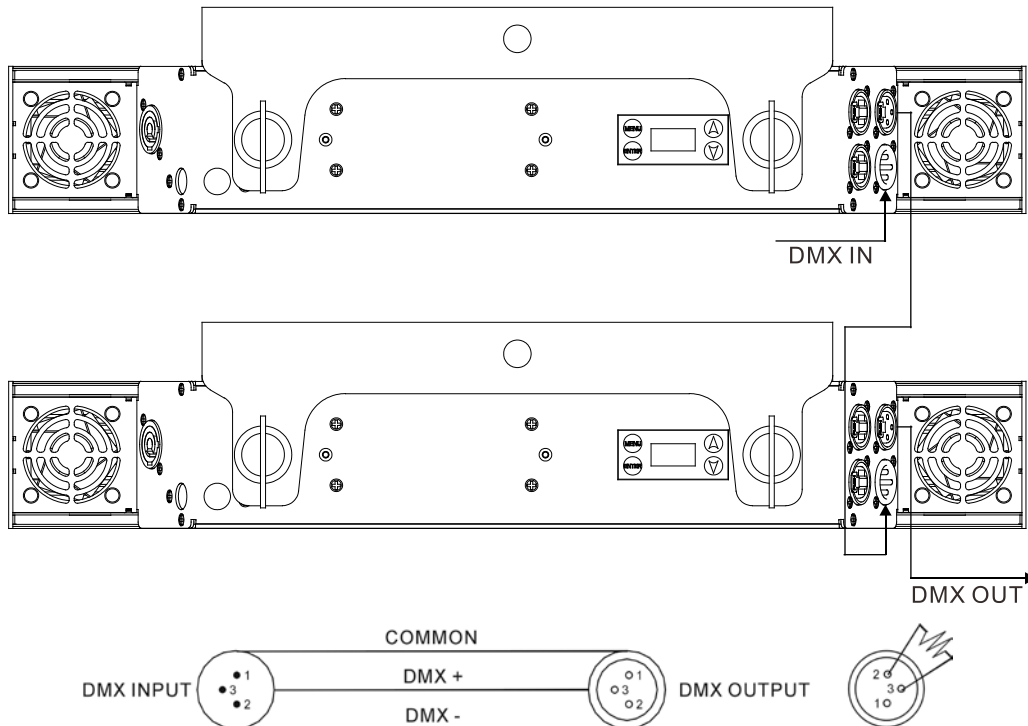

1. At last unit, the DMX cable has to be terminated with a terminator. Solder a 120-ohm 1/4W resistor between pin 2(DMX-) and pin 3(DMX+) into a 3-pin XLR-plug and plug it in the DMX-output of the last unit.
2. Connect the unit together in a “daisy chain” by XLR plug cable from the output of the unit to the input of the next unit. The cable can only be used in series and cannot be connected in parallel. DMX 512 is a very high-speed signal. Inadequate or damaged cables, soldered joints or corroded connectors can easily distort the signal and shut down the system.
3. The DMX output and input connectors are pass-through to maintain the DMX circuit, when one of the units’ power is disconnected.
4. Each lighting unit needs to have a DMX address to receive the data by the controller. The address number is between 1-512.
5. The end of the DMX 512 system should be terminated to reduce signal errors.
6. 3 pin XLR connectors are more popular than 5 pins XLR.  
3 pin XLR: Pin 1: GND, Pin 2: Negative signal (-), Pin 3: Positive signal (+)  
5 pin XLR: Pin 1: GND, Pin 2: Negative signal (-), Pin 3: Positive signal (+), Pin4, Pin5 not used.

## 5.2 Address Setting

If you use a universal DMX controller to control the units, you have to set DMX address from 1 to 512 so that the units can receive DMX signal.

Press the MENU button to enter menu mode, select DMX Settings, press the ENTER button to confirm, use the UP/DOWN button to select DMX Address, press the ENTER button to confirm, the present address will blink in the display, use the UP/DOWN button to adjust the address from 001 to 512, press the ENTER button to store. Press the MENU button back to the last menu or let the unit idle 30 seconds to exit menu mode.

Please refer to the following diagram to address your DMX512 channel for the first 4 units.

Channel Mode	Unit 1 Address	Unit 2 Address	Unit 3 Address	Unit 4 Address
26 Channel	1	27	53	79
10 Channel	1	11	21	31
8 Channel	1	9	17	25
6 Channel	1	7	13	19

## 5.3 DMX512 Configuration

Please control the fixture by referring to the configurations below

### Attentions:

1. The unit will maintain the last condition until reset if you cut-off the DMX signal.
2. For the channel Function, keep the value for about 3 seconds, then the corresponding function will take into effect.

### 26 Channels Mode(Mode 1):

CHANNEL	VALUE	FUNCTION
1	000-007	<b>STROBE</b>
	008-015	Close
	016-131	Open
	132-139	Strobe from Slow to Fast
		Open

	140-181 182-189 190-231 232-239 240-247 248-255	Fast Close Slow Open Open Fast Open Slow Close Open Random Strobe Open
<b>2</b>	000-255	<b>DIMMER</b> 0%→100%
<b>3</b>	000-255	<b>RED1</b> 0%→100%
<b>4</b>	000-255	<b>GREEN1</b> 0%→100%
<b>5</b>	000-255	<b>BLUE1</b> 0%→100%
<b>6</b>	000-255	<b>WHITE1</b> 0%→100%
<b>7</b>	000-255	<b>RED2</b> 0%→100%
<b>8</b>	000-255	<b>GREEN2</b> 0%→100%
<b>9</b>	000-255	<b>BLUE2</b> 0%→100%
<b>10</b>	000-255	<b>WHITE2</b> 0%→100%
<b>11</b>	000-255	<b>RED3</b> 0%→100%
<b>12</b>	000-255	<b>GREEN3</b> 0%→100%
<b>13</b>	000-255	<b>BLUE3</b> 0%→100%
<b>14</b>	000-255	<b>WHITE3</b> 0%→100%
<b>15</b>	000-255	<b>RED4</b> 0%→100%
<b>16</b>	000-255	<b>GREEN4</b> 0%→100%
<b>17</b>	000-255	<b>BLUE4</b> 0%→100%
<b>18</b>	000-255	<b>WHITE4</b> 0%→100%
<b>19</b>		<b>RED5</b>

	000-255	0%→100%
<b>20</b>	000-255	<b>GREEN5</b> 0%→100%
<b>21</b>	000-255	<b>BLUE5</b> 0%→100%
<b>22</b>	000-255	<b>WHITE5</b> 0%→100%
<b>23</b>	000-255	<b>RED6</b> 0%→100%
<b>24</b>	000-255	<b>GREEN6</b> 0%→100%
<b>25</b>	000-255	<b>BLUE6</b> 0%→100%
<b>26</b>	000-255	<b>WHITE6</b> 0%→100%

**10 Channels Mode(Mode 2):**

<b>CHANNEL</b>	<b>VALUE</b>	<b>FUNCTION</b>
<b>1</b>	000-255	<b>RED</b> 0%→100%
<b>2</b>	000-255	<b>GREEN</b> 0%→100%
<b>3</b>	000-255	<b>BLUE</b> 0%→100%
<b>4</b>	000-255	<b>WHITE</b> 0%→100%
<b>5</b>	000-007 008-015 016-131 132-139 140-181 182-189 190-231 232-239 240-247 248-255	<b>STROBE</b> Close Open Strobe from Slow to Fast Open Fast Close Slow Open Open Fast Open Slow Close Open Random Strobe Open
<b>6</b>	000-255	<b>DIMMER</b> 0%→100%

		CTO (8000K-2500K)
	000	Close
	001-004	8000K
	005-009	7900K
	010-013	7800K
	014-018	7700K
	019-022	7600K
	023-027	7500K
	028-031	7400K
	032-036	7300K
	037-040	7200K
	041-045	7100K
	046-049	7000K
	050-054	6900K
	055-058	6800K
	059-063	6700K
	064-067	6600K
	068-072	6500K
	073-076	6400K
	077-081	6300K
	082-085	6200K
7	086-090	6100K
	091-094	6000K
	095-099	5900K
	100-103	5800K
	104-108	5700K
	109-112	5600K
	113-117	5500K
	118-121	5400K
	122-126	5300K
	127-130	5200K
	131-135	5100K
	136-139	5000K
	140-144	4900K
	145-148	4800K
	149-153	4700K
	154-157	4600K
	158-162	4500K
	163-166	4400K
	167-171	4300K
	172-175	4200K
	176-180	4100K
	181-184	4000K
	185-189	3900K

	190-193 194-198 199-202 203-207 208-211 212-216 217-220 221-225 226-229 230-234 235-238 239-243 244-247 248-255	3800K 3700K 3600K 3500K 3400K 3300K 3200K 3100K 3000K 2900K 2800K 2700K 2600K 2500K
8	000-009 010-014 015-019 020-024 025-029 030-034 035-039 040-044 045-049 050-054 055-059 060-064 065-069 070-074 075-079 080-084 085-089 090-094 095-099 100-104 105-109 110-114 115-119 120-124 125-129 130-134 135-139 140-144 145-149	<b>COLOR MACRO</b> Open LEE 790-Moroccan Pink LEE 157-Pink LEE 332-Special Rose Pink LEE 328-Follies Pink LEE 345-Fuchsia Pink LEE 194-Surprise Pink LEE 181-Congo Blue LEE 071-Tokyo Blue LEE 120-Deep Blue LEE 079-Just Blue LEE 132-Medium Blue LEE 200-Double CT Blue LEE 161-State Blue LEE 201-Full CT Blue LEE 202-Half CT Blue LEE 117-Steel Blue LEE 353-Lighter Blue LEE 118-Light Blue LEE 116-Medium Blue Green LEE 124-Dark Green LEE 139-Primary Green LEE 089-Moss Green LEE 122-Fern Green LEE 738-JAS Green LEE 088-Lime Green LEE 100-Spring Yellow LEE 104-Deep Amber LEE 179-Chrome Orange

	150-154 155-159 160-164 165-169 170-174 175-179 180-201 202-207 208-229 230-234 235-239 240-244 245-249 250-255	LEE 105-Orange LEE 021-Gold Amber LEE 778-Millennium Gold LEE 135-Deep Gold Amber LEE 164-Flame Red Open Clockwise Rotation, Fast to Slow Stop Counter-clockwise Rotation, Slow to Fast Open Random Color: Fast Random Color: Medium Random Color: Slow Open
9	000-003 004-007 008-011 012-015 016-019 020-027 028-035 036-043 044-051 052-059 060-067 068-075 076-083 084-091 092-099 100-107 108-115 116-123 124-255	<b>PIXEL EFFECT</b> Open Built-in Effect1 Built-in Effect2 Built-in Effect3 Built-in Effect4 Built-in Effect5 Built-in Effect6 Built-in Effect7 Built-in Effect8 Built-in Effect9 Built-in Effect10 Built-in Effect11 Built-in Effect12 Built-in Effect13 Built-in Effect14 Built-in Effect15 Built-in Effect16 Built-in Effect17 Null
10	000 001-127 128-255	<b>PIXEL EFFECT SPEED</b> Null Slow to Fast without Fade Slow to Fast with Fade

**8 Channels Mode(Mode 3):**

<b>CHANNEL</b>	<b>VALUE</b>	<b>FUNCTION</b>
<b>1</b>	000-255	<b>RED</b> 0%→100%
<b>2</b>	000-255	<b>GREEN</b> 0%→100%
<b>3</b>	000-255	<b>BLUE</b> 0%→100%
<b>4</b>	000-255	<b>WHITE</b> 0%→100%
<b>5</b>	000-007 008-015 016-131 132-139 140-181 182-189 190-231 232-239 240-247 248-255	<b>STROBE</b> Close Open Strobe from Slow to Fast Open Fast Close Slow Open Open Fast Open Slow Close Open Random Strobe Open
<b>6</b>	000-255	<b>DIMMER</b> 0%→100%
<b>7</b>	000 001-004 005-009 010-013 014-018 019-022 023-027 028-031 032-036 037-040 041-045 046-049 050-054 055-058 059-063 064-067 068-072 073-076	<b>CTO (8000K-2500K)</b> Close 8000K 7900K 7800K 7700K 7600K 7500K 7400K 7300K 7200K 7100K 7000K 6900K 6800K 6700K 6600K 6500K 6400K



	077-081	6300K
	082-085	6200K
	086-090	6100K
	091-094	6000K
	095-099	5900K
	100-103	5800K
	104-108	5700K
	109-112	5600K
	113-117	5500K
	118-121	5400K
	122-126	5300K
	127-130	5200K
	131-135	5100K
	136-139	5000K
	140-144	4900K
	145-148	4800K
	149-153	4700K
	154-157	4600K
	158-162	4500K
	163-166	4400K
	167-171	4300K
	172-175	4200K
	176-180	4100K
	181-184	4000K
	185-189	3900K
	190-193	3800K
	194-198	3700K
	199-202	3600K
	203-207	3500K
	208-211	3400K
	212-216	3300K
	217-220	3200K
	221-225	3100K
	226-229	3000K
	230-234	2900K
	235-238	2800K
	239-243	2700K
	244-247	2600K
	248-255	2500K
<b>8</b>	000-009	<b>COLOR MACRO</b>
	010-014	Open
	015-019	LEE 790-Moroccan Pink
	020-024	LEE 157-Pink
		LEE 332-Special Rose Pink

025-029	LEE 328-Follies Pink
030-034	LEE 345-Fuchsia Pink
035-039	LEE 194-Surprise Pink
040-044	LEE 181-Congo Blue
045-049	LEE 071-Tokyo Blue
050-054	LEE 120-Deep Blue
055-059	LEE 079-Just Blue
060-064	LEE 132-Medium Blue
065-069	LEE 200-Double CT Blue
070-074	LEE 161-State Blue
075-079	LEE 201-Full CT Blue
080-084	LEE 202-Half CT Blue
085-089	LEE 117-Steel Blue
090-094	LEE 353-Lighter Blue
095-099	LEE 118-Light Blue
100-104	LEE 116-Medium Blue Green
105-109	LEE 124-Dark Green
110-114	LEE 139-Primary Green
115-119	LEE 089-Moss Green
120-124	LEE 122-Fern Green
125-129	LEE 738-JAS Green
130-134	LEE 088-Lime Green
135-139	LEE 100-Spring Yellow
140-144	LEE 104-Deep Amber
145-149	LEE 179-Chrome Orange
150-154	LEE 105-Orange
155-159	LEE 021-Gold Amber
160-164	LEE 778-Millennium Gold
165-169	LEE 135-Deep Gold Amber
170-174	LEE 164-Flame Red
175-179	Open
180-201	Clockwise Rotation, Fast to Slow
202-207	Stop
208-229	Counter-clockwise Rotation, Slow to Fast
230-234	Open
235-239	Random Color: Fast
240-244	Random Color: Medium
245-249	Random Color: Slow
250-255	Open

**6 Channels Mode(Mode 4):**

<b>CHANNEL</b>	<b>VALUE</b>	<b>FUNCTION</b>
<b>1</b>	000-255	<b>RED</b> 0%→100%
<b>2</b>	000-255	<b>GREEN</b> 0%→100%
<b>3</b>	000-255	<b>BLUE</b> 0%→100%
<b>4</b>	000-255	<b>WHITE</b> 0%→100%
<b>5</b>	000-007 008-015 016-131 132-139 140-181 182-189 190-231 232-239 240-247 248-255	<b>STROBE</b> Close Open Strobe from Slow to Fast Open Fast Close Slow Open Open Fast Open Slow Close Open Random Strobe Open
<b>6</b>	000-255	<b>DIMMER</b> 0%→100%

## **6. Error Information**

**Error codes are shown continuously in the display when the fixture fails and they will not disappear until the fixture is repaired.**

### **1. CPU-B Error**

Check whether the 485 (DATA) leads on the PCB board are installed in place or disconnected.

Check whether the related 485 (DATA) signal circuit on the PCB board is damaged.

### **2. LED Temp. Error**

Check whether the temperature detecting board is normal.

Check whether the components of the temperature detecting board are damaged.

Check whether the lead on the temperature detecting board is installed in place or disconnected.

### **3. LED Too Hot Off**

When the fixture temperature reaches 70°C, it will automatically turn off to protect the fixture.

### **4. LED Timeout Use**

## **7. Troubleshooting**

**Following are a few common problems that may occur during operation. Here are some suggestions for troubleshooting:**

### **A. The unit does not work and no light**

1. Check the connected power.
2. Measure the voltage.
3. Check the power indicator to see whether it can be lit up or not.

### **B. Not responding to the DMX controller**

1. Check whether the DMX connectors and the DMX cables are connected correctly.
2. Check whether the DMX address is correctly set.
3. If the intermittent DMX signal problem occurs, check whether the XLR socket and the signal cable are well connected.
4. Try it with another DMX controller.
5. Check whether the DMX cables run near or alongside to the high-voltage cables, which may damage or interfere with the signal circuit.

## **8. Fixture Cleaning**

It is absolutely essential that the fixture is kept clean to ensure the maximum light-output and allow the fixture to function reliably throughout its life. The fixture must be cleaned regularly to avoid dust, dirt and smoke-fluid residues building up on or within the fixture. The cleaning frequency depends on the application environment. Clean the fixture immediately if the dust enters it to avoid damage to the optical lens due to excessive dust.

- A soft lint-free cloth moistened with any good glass cleaning fluid is recommended, under no circumstances should solvents be used.
- Always dry the parts carefully.
- Clean the external optical lens at least every 20 days.





**Innovation, Quality, Performance**